

**11 Garland Ln**  
Greenville, NY 12083

**\$10.50/sq. ft. NNN**

\*NNN includes but not limited to Real Estate Taxes, Insurance, and CAM (such as parking lot maintenance, snow removal, lawn care, etc.)

**RETAIL SPACE FOR LEASE**

**Aerial - Site View**



**8,000 sq. ft. former Family Dollar store in center with Barbershop, Greenville Pizza, and Greenville Laundromat**

**Just off NYS32 behind Rite Aid with easy ingress/egress**

**Population Density Shading**

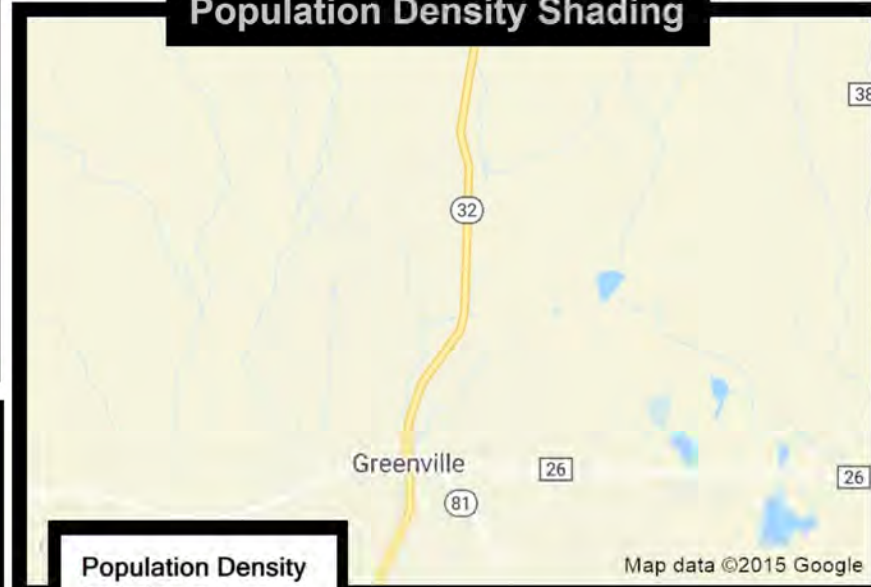

**Population Density**

By Blockgroups

- 7,500 or more
- 5,000 to 7,500
- 2,500 to 5,000
- 1,000 to 2,500
- Less than 1,000

**Demographic Data**

	3 mi radius	5 mi radius	10 mi radius
Population (2019)	2,834	5,609	22,150
Households (2019)	1,258	2,475	9,794
Median household income (2019)	\$70,602	\$67,856	\$67,514
Total Employees	1,090	1,375	4,396
Total Establishments	138	185	586

**COCCA DEVELOPMENT, LTD**

100 DEBAROLO PLACE SUITE 400 BOARDMAN, OHIO 44512  
(330) 729-1010

[WWW.COCCADEVELOPMENT.COM](http://WWW.COCCADEVELOPMENT.COM)

This map was produced using data from private and government sources deemed to be reliable. The information herein is provided without representation or warranty.



PROPOSED SITE PLAN

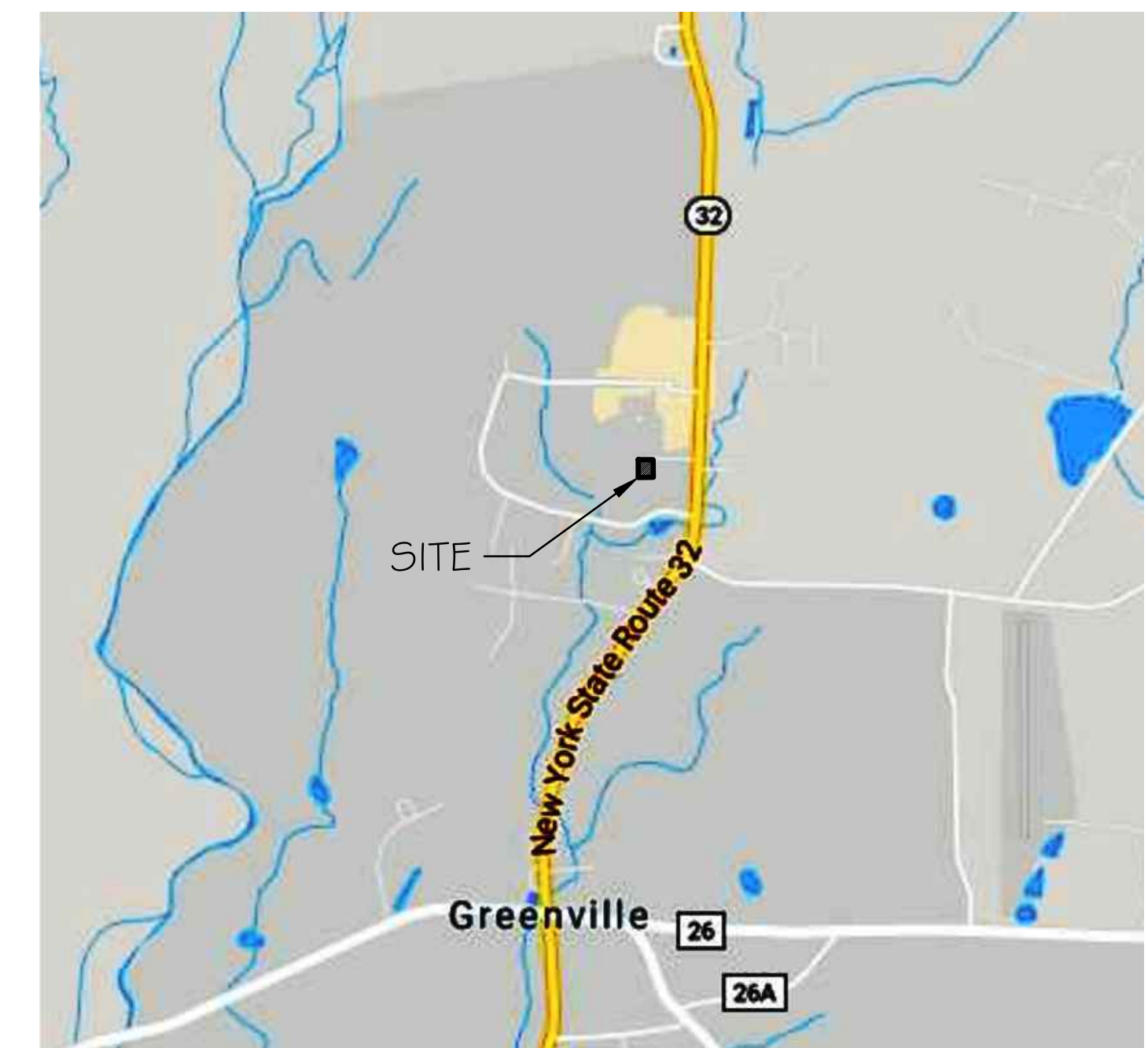
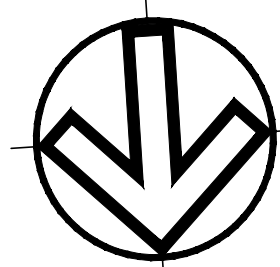

SITE LOCATION MAP

NOT TO SCALE  
COPYRIGHT: 2018 GOOGLE

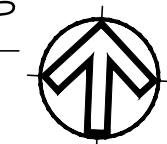

NOTES:

- SUBJECT PROPERTY BOUNDARIES ARE REFERENCED FROM A CAROL BRYANT SUBDIVISION PLAN THAT WAS APPROVED BY THE TOWN OF GREENVILLE PLANNING BOARD ON NOVEMBER 7, 1996.
- THE AERIAL IMAGE SHOWN REPRESENTS 2016 AERIAL IMAGERY AND WAS OBTAINED FROM THE GREENE COUNTY WEB MAP GIS. ACTUAL FIELD CONDITIONS MAY VARY.
- CONTRACTOR MUST CONTACT NEW YORK 811 FOR UTILITY MARK-OUTS AT LEAST 2 FULL BUSINESS DAYS NOT INCLUDING THE DAY OF CALL, PRIOR TO DIGGING BY DIALING 811.
- PROPOSED STRIPING SHALL BE LATEX TRAFFIC PAINT BY BENJAMIN MOORE #TD-58 LOW VOC IN WHITE AT 4-INCHES WIDE OR APPROVED EQUAL. APPLICATION RATE SHALL BE 1.5 MILS WET FILM THICKNESS FOR NEW LINES AND 1.0 MILS FOR EXISTING LINES.

PARKING SUMMARY:

- EXISTING NUMBER OF PARKING SPACES: 26
- PROPOSED NUMBER OF PARKING SPACES: 39

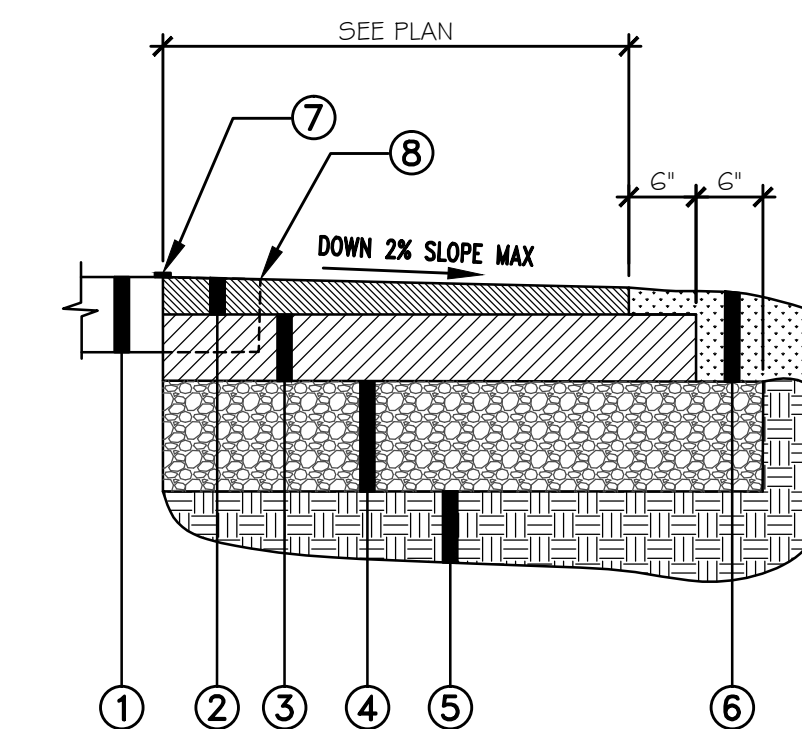

LEGEND:

- EXISTING ASPHALT PAVEMENT
- PROPOSED 1" ASPHALT CONCRETE SURFACE COURSE, PITCHED AT MAX 2% SLOPE TOWARD THE RIGHT-OF-WAY
- PROPOSED 2" ASPHALT CONCRETE SURFACE COURSE
- PROPOSED 6" AGGREGATE BASE
- COMPACTED SUBGRADE TO 98% OF ASTM D698
- RESTORATION AS REQUIRED, TOPSOIL FURNISHED AND PLACED, 4" THICK OVER COMPACTED SUBGRADE
- ASPHALT JOINT SEALANT, 4" WIDE
- SAWCUT EXISTING PAVEMENT 1-FT FROM EXISTING EDGE AND REMOVE ASPHALT AND EARTH MATERIAL AS REQUIRED FOR NEW PAVEMENT SECTION

PROPOSED PAVEMENT SECTION

NOT TO SCALE

COCCA DEVELOPMENT LTD.

100 DeBARTOLO PLACE, SUITE 400  
BOARDMAN, OH 44512  
PHONE: 330-729-1010  
FAX: 330-729-1008

REVISIONS:

PROJECT:  
EXISTING RETAIL PLAZA  
11 GARLAND LANE  
GREENVILLE, NY 12083  
COUNTY OF GREENE

DRAWING TITLE:

**SITE PLAN**

CHECKED BY:

DATE: 12/20/18

SCALE: 1" = 20'

DRAWN BY: JAW

SHEET #

**C-1.0**

11 Garland Ln  
Greenville, NY 12083

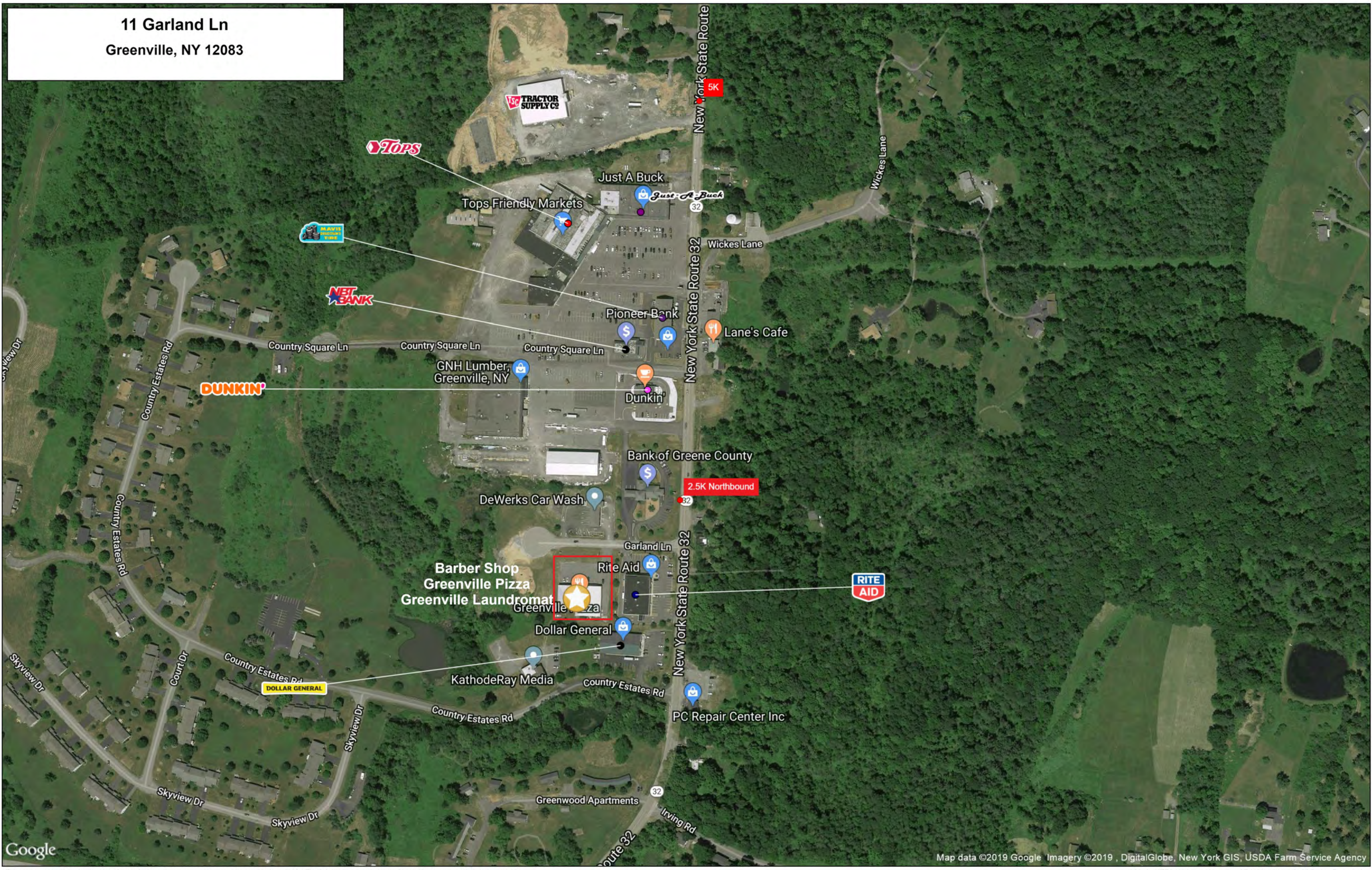

**11 Garland Ln  
Greenville, NY 12083**

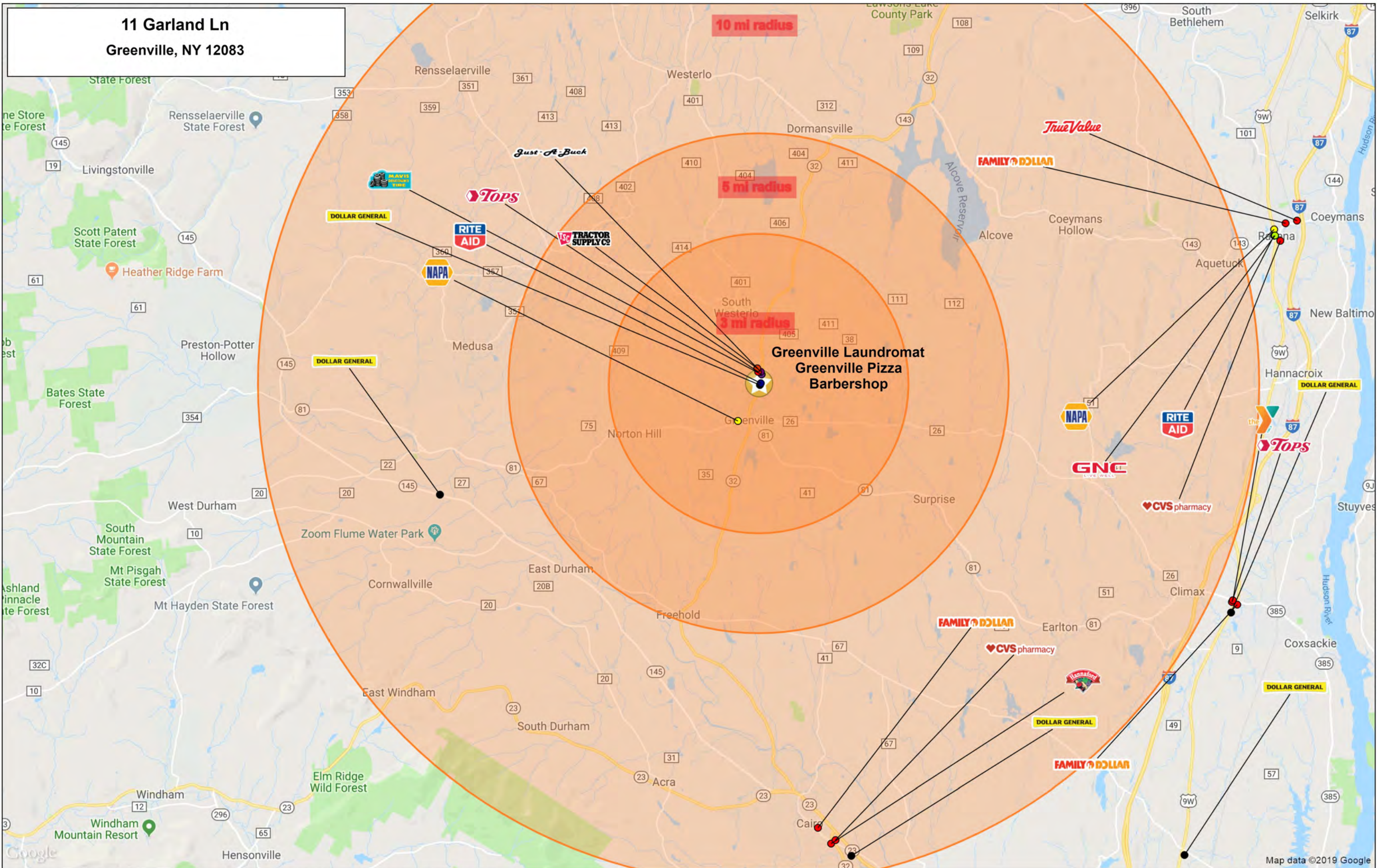

This map was produced using data from private and government sources deemed to be reliable. The information herein is provided without representation or warranty

©2019, SITES USA Inc., Chandler, AZ (480) 491-1112. All Rights Reserved.

Lat: 42.41052 Long: -74.04607 Zoom: 12  
Logos are for identification purposes only and may be trademarks of their respective companies.

# GRAPHIC PROFILE

2000-2010 Census, 2019 Estimates with 2024 Projections

Calculated using Weighted Block Centroid from Block Groups

Lat/Lon: 42.4256/-74.0186

RGRAP3

## 11 Garland Ln

### Greenville, NY 12083

3 mi radius

5 mi radius

10 mi radius

#### Population

Estimated Population (2019)	2,834	5,609	22,150
Projected Population (2024)	2,694	5,363	21,775
Census Population (2010)	2,942	5,808	22,867
Census Population (2000)	2,634	5,414	22,389
Projected Annual Growth (2019-2024)	-140 -1.0%	-246 -0.9%	-375 -0.3%
Historical Annual Growth (2010-2019)	-108 -0.4%	-199 -0.4%	-717 -0.4%
Historical Annual Growth (2000-2010)	308 1.2%	394 0.7%	478 0.2%
Estimated Population Density (2019)	100 <i>psm</i>	71 <i>psm</i>	71 <i>psm</i>
Trade Area Size	28.3 <i>sq mi</i>	78.5 <i>sq mi</i>	314.0 <i>sq mi</i>

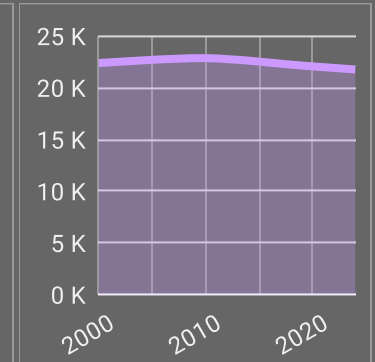
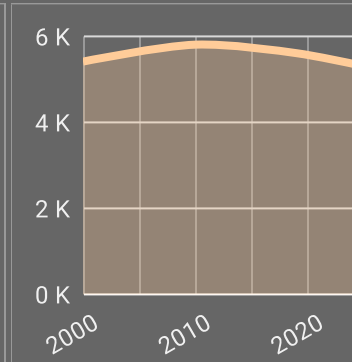
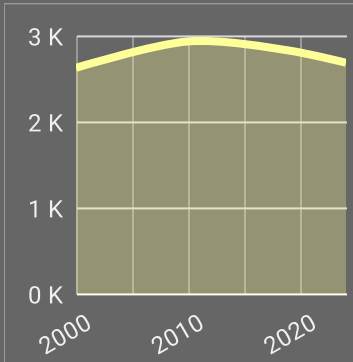

#### Race and Ethnicity (2019)

Not Hispanic or Latino Population	2,733 96.4%	5,425 96.7%	21,328 96.3%
White	2,610 95.5%	5,207 96.0%	20,430 95.8%
Black or African American	32 1.2%	59 1.1%	284 1.3%
American Indian or Alaska Native	5 0.2%	9 0.2%	38 0.2%
Asian	47 1.7%	80 1.5%	247 1.2%
Hawaiian or Pacific Islander	- -	- -	4 -
Other Race	2 -	2 -	12 -
Two or More Races	38 1.4%	67 1.2%	314 1.5%
Hispanic or Latino Population	101 3.6%	184 3.3%	822 3.7%
White	64 63.5%	120 64.9%	573 69.7%
Black or African American	14 13.6%	23 12.5%	62 7.6%
American Indian or Alaska Native	- -	1 0.6%	11 1.3%
Asian	- -	1 0.6%	16 1.9%
Hispanic Hawaiian or Pacific Islander	- -	- -	4 0.5%
Other Race	12 12.3%	23 12.4%	91 11.0%
Two or More Races	10 10.1%	16 8.9%	66 8.0%

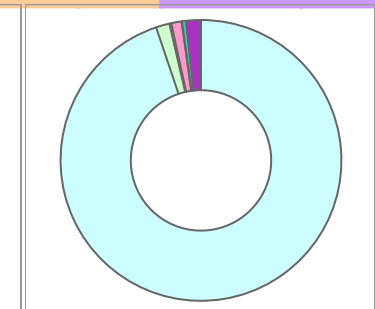
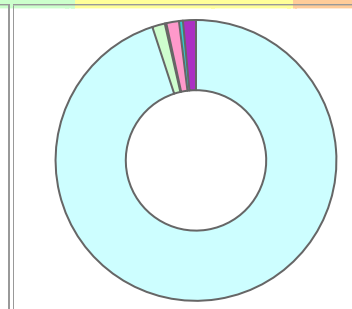
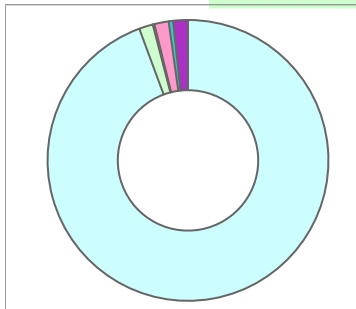

White Black or African American American Indian or Alaska Native Asian Hawaiian or Pacific Islander Other Race 2+ Races

This report was produced using data from private and government sources deemed to be reliable. The information herein is provided without representation or warranty.

# GRAPHIC PROFILE

2000-2010 Census, 2019 Estimates with 2024 Projections

Calculated using Weighted Block Centroid from Block Groups

Lat/Lon: 42.4256/-74.0186

RGRAP3

## 11 Garland Ln

Greenville, NY 12083

3 mi radius

5 mi radius

10 mi radius

### Age Distribution (2019)

Age Group	3 mi radius	5 mi radius	10 mi radius
Age Under 5 Years	150 5.3%	281 5.0%	1,020 4.6%
Age 5 to 9 Years	149 5.3%	297 5.3%	1,062 4.8%
Age 10 to 14 Years	146 5.2%	293 5.2%	1,183 5.3%
Age 15 to 19 Years	157 5.5%	309 5.5%	1,219 5.5%
Age 20 to 24 Years	148 5.2%	300 5.3%	1,182 5.3%
Age 25 to 29 Years	156 5.5%	303 5.4%	1,246 5.6%
Age 30 to 34 Years	142 5.0%	280 5.0%	1,145 5.2%
Age 35 to 39 Years	159 5.6%	304 5.4%	1,192 5.4%
Age 40 to 44 Years	151 5.3%	299 5.3%	1,269 5.7%
Age 45 to 49 Years	185 6.5%	368 6.6%	1,454 6.6%
Age 50 to 54 Years	213 7.5%	429 7.7%	1,673 7.6%
Age 55 to 59 Years	235 8.3%	467 8.3%	1,816 8.2%
Age 60 to 64 Years	192 6.8%	409 7.3%	1,746 7.9%
Age 65 to 69 Years	214 7.6%	424 7.6%	1,678 7.6%
Age 70 to 74 Years	160 5.6%	320 5.7%	1,428 6.4%
Age 75 to 79 Years	118 4.2%	225 4.0%	860 3.9%
Age 80 to 84 Years	81 2.9%	146 2.6%	516 2.3%
Age 85 Years or Over	77 2.7%	152 2.7%	462 2.1%
Median Age	45.7	45.9	46.0

### Generation (2019)

Generation	3 mi radius	5 mi radius	10 mi radius
iGeneration (Age Under 15 Years)	446 15.7%	871 15.5%	3,265 14.7%
Generation 9/11 Millennials (Age 15 to 34 Years)	603 21.3%	1,193 21.3%	4,792 21.6%
Gen Xers (Age 35 to 49 Years)	495 17.5%	971 17.3%	3,914 17.7%
Baby Boomers (Age 50 to 74 Years)	1,015 35.8%	2,051 36.6%	8,341 37.7%
Silent Generation (Age 75 to 84 Years)	198 7.0%	371 6.6%	1,376 6.2%
G.I. Generation (Age 85 Years or Over)	77 2.7%	152 2.7%	462 2.1%

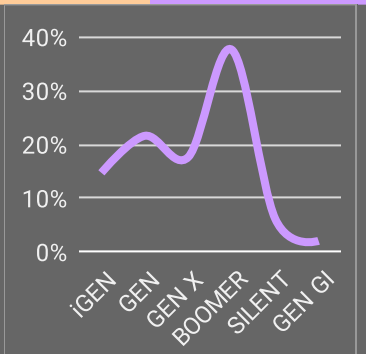
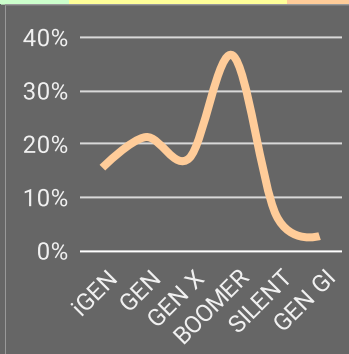
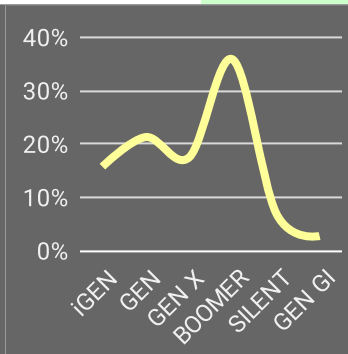

This report was produced using data from private and government sources deemed to be reliable. The information herein is provided without representation or warranty.

# GRAPHIC PROFILE

2000-2010 Census, 2019 Estimates with 2024 Projections

Calculated using Weighted Block Centroid from Block Groups

Lat/Lon: 42.4256/-74.0186

RGRAP3

## 11 Garland Ln

Greenville, NY 12083

3 mi radius

5 mi radius

10 mi radius

### Household Type (2019)

	3 mi radius	5 mi radius	10 mi radius
Total Households	1,258	2,475	9,794
Family Households	780 62.0%	1,562 63.1%	6,270 64.0%
Family Households with Children	317 40.7%	625 40.0%	2,430 38.8%
Family Households No Children	463 59.3%	936 60.0%	3,840 61.2%
Non-Family Households	479 38.0%	913 36.9%	3,524 36.0%
Non-Family Households with Children	4 0.8%	6 0.6%	28 0.8%
Non-Family Households No Children	475 99.2%	908 99.4%	3,496 99.2%

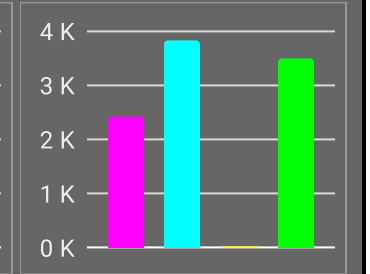
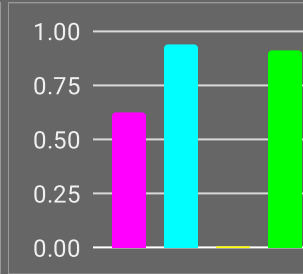
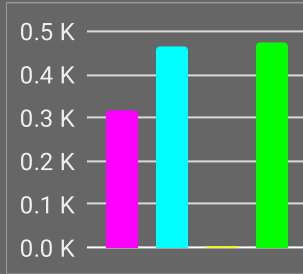

### Education Attainment (2019)

	3 mi radius	5 mi radius	10 mi radius
Elementary or Some High School	185 8.9%	326 7.9%	1,682 10.2%
High School Graduate	766 36.8%	1,556 37.7%	5,988 36.3%
Some College or Associate Degree	629 30.2%	1,211 29.3%	4,804 29.1%
Bachelor or Graduate Degree	502 24.1%	1,036 25.1%	4,011 24.3%

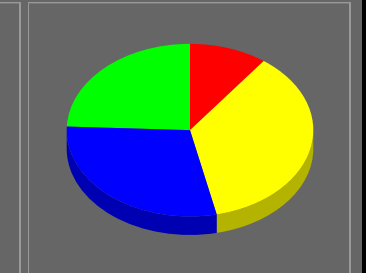
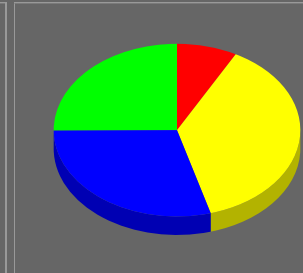
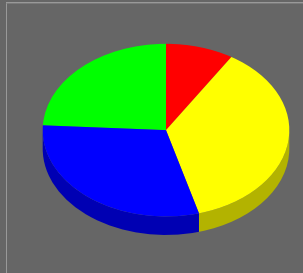

### Household Income (2019)

	3 mi radius	5 mi radius	10 mi radius
Estimated Average Household Income	\$80,417	\$77,922	\$70,105
Estimated Median Household Income	\$70,602	\$67,856	\$67,514
HH Income Under \$10,000	16 1.3%	40 1.6%	203 2.1%
HH Income \$10,000 to \$34,999	215 17.1%	475 19.2%	2,188 22.3%
HH Income \$35,000 to \$49,999	209 16.6%	412 16.6%	1,239 12.6%
HH Income \$50,000 to \$74,999	219 17.4%	413 16.7%	1,727 17.6%
HH Income \$75,000 to \$99,999	198 15.8%	385 15.6%	1,654 16.9%
HH Income \$100,000 to \$149,999	303 24.1%	529 21.4%	1,783 18.2%
HH Income \$150,000 or More	98 7.8%	221 8.9%	1,001 10.2%

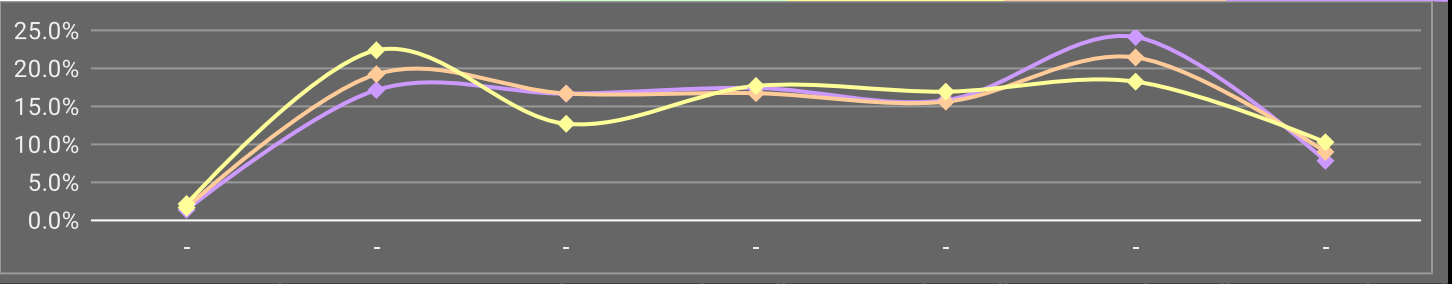

This report was produced using data from private and government sources deemed to be reliable. The information herein is provided without representation or warranty.

# EXPANDED PROFILE

2000-2010 Census, 2019 Estimates with 2024 Projections

Calculated using Weighted Block Centroid from Block Groups

Lat/Lon: 42.4256/-74.0186

RF5

## 11 Garland Ln

### Greenville, NY 12083

#### Population

	3 mi radius		5 mi radius		10 mi radius	
Estimated Population (2019)	2,834		5,609		22,150	
Projected Population (2024)	2,694		5,363		21,775	
Census Population (2010)	2,942		5,808		22,867	
Census Population (2000)	2,634		5,414		22,389	
Projected Annual Growth (2019 to 2024)	-140	-1.0%	-246	-0.9%	-375	-0.3%
Historical Annual Growth (2010 to 2019)	-108	-0.4%	-199	-0.4%	-717	-0.4%
Historical Annual Growth (2000 to 2010)	308	1.2%	394	0.7%	478	0.2%
Estimated Population Density (2019)	100 psm		71 psm		71 psm	
Trade Area Size	28.3 sq mi		78.5 sq mi		314.0 sq mi	

#### Households

Estimated Households (2019)	1,258		2,475		9,794	
Projected Households (2024)	1,206		2,387		9,719	
Census Households (2010)	1,212		2,378		9,391	
Census Households (2000)	1,067		2,154		8,766	
Estimated Households with Children (2019)	321	25.5%	631	25.5%	2,458	25.1%
Estimated Average Household Size (2019)	2.25		2.26		2.26	

#### Average Household Income

Estimated Average Household Income (2019)	\$80,417		\$77,922		\$70,105	
Projected Average Household Income (2024)	\$100,117		\$96,483		\$83,839	
Estimated Average Family Income (2019)	\$105,752		\$101,484		\$87,633	

#### Median Household Income

Estimated Median Household Income (2019)	\$70,602		\$67,856		\$67,514	
Projected Median Household Income (2024)	\$82,130		\$79,131		\$78,033	
Estimated Median Family Income (2019)	\$90,352		\$84,045		\$84,311	

#### Per Capita Income

Estimated Per Capita Income (2019)	\$35,730		\$34,393		\$31,019	
Projected Per Capita Income (2024)	\$44,850		\$42,953		\$37,444	
Estimated Per Capita Income 5 Year Growth	\$9,120	25.5%	\$8,561	24.9%	\$6,424	20.7%
Estimated Average Household Net Worth (2019)	\$617,752		\$633,351		\$649,784	

#### Daytime Demos (2019)

Total Businesses	138		185		586	
Total Employees	1,090		1,375		4,396	
Company Headquarter Businesses	-	-	-	-	-	-
Company Headquarter Employees	-	-	-	-	-	-
Employee Population per Business	7.9		7.4		7.5	
Residential Population per Business	20.5		30.3		37.8	

This report was produced using data from private and government sources deemed to be reliable. The information herein is provided without representation or warranty.



# EXPANDED PROFILE

2000-2010 Census, 2019 Estimates with 2024 Projections

Calculated using Weighted Block Centroid from Block Groups

Lat/Lon: 42.4256/-74.0186

RF5

## 11 Garland Ln

### Greenville, NY 12083

#### Race & Ethnicity

	3 mi radius		5 mi radius		10 mi radius	
White (2019)	2,674	94.3%	5,327	95.0%	21,003	94.8%
Black or African American (2019)	45	1.6%	82	1.5%	346	1.6%
American Indian or Alaska Native (2019)	6	0.2%	10	0.2%	49	0.2%
Asian (2019)	47	1.6%	82	1.5%	263	1.2%
Hawaiian or Pacific Islander (2019)	-	-	-	-	8	-
Other Race (2019)	14	0.5%	25	0.5%	103	0.5%
Two or More Races (2019)	48	1.7%	84	1.5%	380	1.7%
Not Hispanic or Latino Population (2019)	2,733	96.4%	5,425	96.7%	21,328	96.3%
Hispanic or Latino Population (2019)	101	3.6%	184	3.3%	822	3.7%
Not Hispanic or Latino Population (2024)	2,588	96.1%	5,168	96.4%	20,850	95.7%
Hispanic or Latino Population (2024)	106	3.9%	195	3.6%	926	4.3%
Not Hispanic or Latino Population (2010)	2,868	97.5%	5,676	97.7%	22,255	97.3%
Hispanic or Latino Population (2010)	74	2.5%	132	2.3%	612	2.7%
Not Hispanic or Latino Population (2000)	2,595	98.5%	5,333	98.5%	21,921	97.9%
Hispanic or Latino Population (2000)	39	1.5%	81	1.5%	468	2.1%
Projected Hispanic Annual Growth (2019 to 2024)	5	1.0%	11	1.2%	103	2.5%
Historic Hispanic Annual Growth (2000 to 2019)	62	8.3%	103	6.7%	355	4.0%

#### Age Distribution (2019)

Age Under 5	150	5.3%	281	5.0%	1,020	4.6%
Age 5 to 9 Years	149	5.3%	297	5.3%	1,062	4.8%
Age 10 to 14 Years	146	5.2%	293	5.2%	1,183	5.3%
Age 15 to 19 Years	157	5.5%	309	5.5%	1,219	5.5%
Age 20 to 24 Years	148	5.2%	300	5.3%	1,182	5.3%
Age 25 to 29 Years	156	5.5%	303	5.4%	1,246	5.6%
Age 30 to 34 Years	142	5.0%	280	5.0%	1,145	5.2%
Age 35 to 39 Years	159	5.6%	304	5.4%	1,192	5.4%
Age 40 to 44 Years	151	5.3%	299	5.3%	1,269	5.7%
Age 45 to 49 Years	185	6.5%	368	6.6%	1,454	6.6%
Age 50 to 54 Years	213	7.5%	429	7.7%	1,673	7.6%
Age 55 to 59 Years	235	8.3%	467	8.3%	1,816	8.2%
Age 60 to 64 Years	192	6.8%	409	7.3%	1,746	7.9%
Age 65 to 74 Years	374	13.2%	745	13.3%	3,106	14.0%
Age 75 to 84 Years	198	7.0%	371	6.6%	1,376	6.2%
Age 85 Years or Over	77	2.7%	152	2.7%	462	2.1%
Median Age	45.7		45.9		46.0	

#### Gender Age Distribution (2019)

Female Population	1,429	50.4%	2,805	50.0%	11,045	49.9%
Age 0 to 19 Years	285	19.9%	558	19.9%	2,178	19.7%
Age 20 to 64 Years	797	55.8%	1,575	56.2%	6,321	57.2%
Age 65 Years or Over	347	24.3%	671	23.9%	2,546	23.1%
Female Median Age	45.9		46.3		46.0	
Male Population	1,405	49.6%	2,804	50.0%	11,105	50.1%
Age 0 to 19 Years	318	22.6%	622	22.2%	2,307	20.8%
Age 20 to 64 Years	784	55.8%	1,586	56.5%	6,401	57.6%
Age 65 Years or Over	303	21.5%	597	21.3%	2,398	21.6%
Male Median Age	45.4		45.5		45.8	

This report was produced using data from private and government sources deemed to be reliable. The information herein is provided without representation or warranty.

# EXPANDED PROFILE

2000-2010 Census, 2019 Estimates with 2024 Projections

Calculated using Weighted Block Centroid from Block Groups

Lat/Lon: 42.4256/-74.0186

RF5

## 11 Garland Ln

### Greenville, NY 12083

3 mi radius

5 mi radius

10 mi radius

#### Household Income Distribution (2019)

Income Category	3 mi radius	5 mi radius	10 mi radius
HH Income \$200,000 or More	51 4.1%	101 4.1%	383 3.9%
HH Income \$150,000 to \$199,999	47 3.7%	120 4.9%	618 6.3%
HH Income \$100,000 to \$149,999	303 24.1%	529 21.4%	1,783 18.2%
HH Income \$75,000 to \$99,999	198 15.8%	385 15.6%	1,654 16.9%
HH Income \$50,000 to \$74,999	219 17.4%	413 16.7%	1,727 17.6%
HH Income \$35,000 to \$49,999	209 16.6%	412 16.6%	1,239 12.6%
HH Income \$25,000 to \$34,999	90 7.1%	195 7.9%	814 8.3%
HH Income \$15,000 to \$24,999	74 5.9%	202 8.2%	1,045 10.7%
HH Income Under \$15,000	68 5.4%	118 4.8%	532 5.4%
HH Income \$35,000 or More	1,027 81.6%	1,960 79.2%	7,403 75.6%
HH Income \$75,000 or More	599 47.6%	1,136 45.9%	4,437 45.3%

#### Housing (2019)

Housing Category	3 mi radius	5 mi radius	10 mi radius
Total Housing Units	1,475	2,996	12,222
Housing Units Occupied	1,258 85.3%	2,475 82.6%	9,794 80.1%
Housing Units Owner-Occupied	1,030 81.8%	2,019 81.6%	7,887 80.5%
Housing Units, Renter-Occupied	229 18.2%	456 18.4%	1,907 19.5%
Housing Units, Vacant	216 17.2%	521 21.1%	2,428 24.8%

#### Marital Status (2019)

Marital Status	3 mi radius	5 mi radius	10 mi radius
Never Married	772 32.3%	1,491 31.5%	5,653 29.9%
Currently Married	1,175 49.2%	2,415 51.0%	9,339 49.5%
Separated	38 1.6%	80 1.7%	843 4.5%
Widowed	161 6.8%	317 6.7%	1,110 5.9%
Divorced	243 10.2%	435 9.2%	1,941 10.3%

#### Household Type (2019)

Household Type	3 mi radius	5 mi radius	10 mi radius
Population Family	2,261 79.8%	4,511 80.4%	17,904 80.8%
Population Non-Family	568 20.0%	1,092 19.5%	4,202 19.0%
Population Group Quarters	5 0.2%	6 0.1%	44 0.2%
Family Households	780 62.0%	1,562 63.1%	6,270 64.0%
Non-Family Households	479 38.0%	913 36.9%	3,524 36.0%
Married Couple with Children	233 19.9%	452 18.7%	1,645 17.6%
Average Family Household Size	2.9	2.9	2.9

#### Household Size (2019)

Household Size	3 mi radius	5 mi radius	10 mi radius
1 Person Households	408 32.4%	770 31.1%	2,939 30.0%
2 Person Households	483 38.4%	964 39.0%	3,866 39.5%
3 Person Households	150 11.9%	303 12.3%	1,299 13.3%
4 Person Households	121 9.7%	251 10.1%	1,015 10.4%
5 Person Households	57 4.6%	114 4.6%	453 4.6%
6 or More Person Households	39 3.1%	72 2.9%	222 2.3%

#### Household Vehicles (2019)

Vehicles Category	3 mi radius	5 mi radius	10 mi radius
Households with 0 Vehicles Available	78 6.2%	124 5.0%	475 4.8%
Households with 1 Vehicles Available	352 28.0%	685 27.7%	2,820 28.8%
Households with 2 or More Vehicles Available	828 65.8%	1,666 67.3%	6,499 66.4%
Total Vehicles Available	2,426	4,902	19,411
Average Vehicles Per Household	1.9	2.0	2.0

This report was produced using data from private and government sources deemed to be reliable. The information herein is provided without representation or warranty.

# EXPANDED PROFILE

2000-2010 Census, 2019 Estimates with 2024 Projections

Calculated using Weighted Block Centroid from Block Groups

Lat/Lon: 42.4256/-74.0186

RF5

## 11 Garland Ln

### Greenville, NY 12083

#### Labor Force (2019)

	3 mi radius		5 mi radius		10 mi radius	
Estimated Labor Population Age 16 Years or Over	2,359		4,684		18,676	
Estimated Civilian Employed	1,384	58.7%	2,717	58.0%	10,887	58.3%
Estimated Civilian Unemployed	44	1.9%	113	2.4%	383	2.1%
Estimated in Armed Forces	-	-	-	-	7	-
Estimated Not in Labor Force	931	39.5%	1,854	39.6%	7,398	39.6%
Unemployment Rate	1.9%		2.4%		2.1%	

#### Occupation (2019)

	3 mi radius		5 mi radius		10 mi radius	
Occupation: Population Age 16 Years or Over	1,384		2,717		10,887	
Management, Business, Financial Operations	161	11.7%	326	12.0%	1,454	13.4%
Professional, Related	293	21.2%	617	22.7%	2,485	22.8%
Service	225	16.3%	421	15.5%	1,692	15.5%
Sales, Office	261	18.9%	520	19.1%	2,293	21.1%
Farming, Fishing, Forestry	4	0.3%	6	0.2%	16	0.1%
Construct, Extraction, Maintenance	222	16.0%	402	14.8%	1,228	11.3%
Production, Transport Material Moving	218	15.8%	426	15.7%	1,720	15.8%
White Collar Workers	716	51.7%	1,462	53.8%	6,232	57.2%
Blue Collar Workers	669	48.3%	1,255	46.2%	4,656	42.8%

#### Consumer Expenditure (2019)

	3 mi radius		5 mi radius		10 mi radius	
Total Household Expenditure	\$75.95 M		\$145.88 M		\$537.64 M	
Total Non-Retail Expenditure	\$39.87 M	52.5%	\$76.63 M	52.5%	\$282.67 M	52.6%
Total Retail Expenditure	\$36.08 M	47.5%	\$69.25 M	47.5%	\$254.97 M	47.4%
Apparel	\$2.63 M	3.5%	\$5.06 M	3.5%	\$18.64 M	3.5%
Contributions	\$2.46 M	3.2%	\$4.74 M	3.2%	\$17.46 M	3.2%
Education	\$2.09 M	2.8%	\$4.04 M	2.8%	\$15.01 M	2.8%
Entertainment	\$4.29 M	5.6%	\$8.24 M	5.7%	\$30.37 M	5.6%
Food and Beverages	\$11.22 M	14.8%	\$21.53 M	14.8%	\$79.34 M	14.8%
Furnishings and Equipment	\$2.68 M	3.5%	\$5.14 M	3.5%	\$18.93 M	3.5%
Gifts	\$1.83 M	2.4%	\$3.5 M	2.4%	\$12.84 M	2.4%
Health Care	\$6.61 M	8.7%	\$12.7 M	8.7%	\$46.79 M	8.7%
Household Operations	\$2.97 M	3.9%	\$5.71 M	3.9%	\$21.06 M	3.9%
Miscellaneous Expenses	\$1.45 M	1.9%	\$2.77 M	1.9%	\$10.2 M	1.9%
Personal Care	\$1.02 M	1.3%	\$1.97 M	1.3%	\$7.24 M	1.3%
Personal Insurance	\$533.9 K	0.7%	\$1.03 M	0.7%	\$3.79 M	0.7%
Reading	\$167.22 K	0.2%	\$321.25 K	0.2%	\$1.18 M	0.2%
Shelter	\$15.83 M	20.8%	\$30.44 M	20.9%	\$112.34 M	20.9%
Tobacco	\$467.89 K	0.6%	\$899.55 K	0.6%	\$3.32 M	0.6%
Transportation	\$14 M	18.4%	\$26.86 M	18.4%	\$98.75 M	18.4%
Utilities	\$5.7 M	7.5%	\$10.94 M	7.5%	\$40.36 M	7.5%

#### Educational Attainment (2019)

	3 mi radius		5 mi radius		10 mi radius	
Adult Population Age 25 Years or Over	2,083		4,129		16,484	
Elementary (Grade Level 0 to 8)	31	1.5%	68	1.6%	297	1.8%
Some High School (Grade Level 9 to 11)	155	7.4%	258	6.2%	1,385	8.4%
High School Graduate	766	36.8%	1,556	37.7%	5,988	36.3%
Some College	334	16.0%	643	15.6%	2,505	15.2%
Associate Degree Only	295	14.2%	568	13.8%	2,299	13.9%
Bachelor Degree Only	285	13.7%	541	13.1%	2,217	13.5%
Graduate Degree	217	10.4%	494	12.0%	1,794	10.9%

This report was produced using data from private and government sources deemed to be reliable. The information herein is provided without representation or warranty.

# EXPANDED PROFILE

2000-2010 Census, 2019 Estimates with 2024 Projections

Calculated using Weighted Block Centroid from Block Groups

Lat/Lon: 42.4256/-74.0186

RF5

## 11 Garland Ln

### Greenville, NY 12083

#### Units In Structure (2019)

	3 mi radius		5 mi radius		10 mi radius	
1 Detached Unit	895	73.9%	1,827	76.8%	7,429	79.1%
1 Attached Unit	112	9.3%	141	5.9%	280	3.0%
2 to 4 Units	137	11.3%	265	11.1%	842	9.0%
5 to 9 Units	4	0.3%	13	0.5%	127	1.4%
10 to 19 Units	12	1.0%	24	1.0%	107	1.1%
20 to 49 Units	4	0.3%	8	0.3%	68	0.7%
50 or More Units	11	0.9%	27	1.1%	111	1.2%
Mobile Home or Trailer	82	6.8%	169	7.1%	829	8.8%
Other Structure	-	-	-	-	-	-

#### Homes Built By Year (2019)

Homes Built 2010 or later	44	3.7%	71	3.0%	211	2.2%
Homes Built 2000 to 2009	165	13.6%	280	11.8%	1,118	11.9%
Homes Built 1990 to 1999	163	13.4%	324	13.6%	1,158	12.3%
Homes Built 1980 to 1989	174	14.4%	343	14.4%	1,226	13.1%
Homes Built 1970 to 1979	109	9.0%	258	10.8%	1,473	15.7%
Homes Built 1960 to 1969	130	10.8%	269	11.3%	844	9.0%
Homes Built 1950 to 1959	117	9.6%	222	9.3%	803	8.5%
Homes Built Before 1949	356	29.4%	709	29.8%	2,962	31.5%

#### Home Values (2019)

Home Values \$1,000,000 or More	1	0.1%	7	0.4%	83	1.1%
Home Values \$500,000 to \$999,999	31	3.2%	75	3.9%	366	4.9%
Home Values \$400,000 to \$499,999	19	1.9%	46	2.4%	208	2.8%
Home Values \$300,000 to \$399,999	84	8.5%	175	9.0%	743	9.9%
Home Values \$200,000 to \$299,999	262	26.5%	552	28.5%	2,002	26.5%
Home Values \$150,000 to \$199,999	307	31.1%	525	27.1%	1,856	24.6%
Home Values \$100,000 to \$149,999	176	17.9%	330	17.0%	1,467	19.5%
Home Values \$70,000 to \$99,999	48	4.8%	135	6.9%	542	7.2%
Home Values \$50,000 to \$69,999	54	5.5%	97	5.0%	266	3.5%
Home Values \$25,000 to \$49,999	3	0.3%	12	0.6%	139	1.8%
Home Values Under \$25,000	44	4.4%	62	3.2%	185	2.5%
Owner-Occupied Median Home Value	\$182,330		\$188,510		\$190,815	
Renter-Occupied Median Rent	\$766		\$769		\$732	

#### Transportation To Work (2019)

Drive to Work Alone	1,046	82.1%	2,113	83.3%	8,488	83.8%
Drive to Work in Carpool	135	10.6%	251	9.9%	810	8.0%
Travel to Work by Public Transportation	16	1.2%	27	1.1%	138	1.4%
Drive to Work on Motorcycle	-	-	1	-	14	0.1%
Walk or Bicycle to Work	28	2.2%	51	2.0%	150	1.5%
Other Means	-	-	5	0.2%	117	1.2%
Work at Home	50	3.9%	88	3.5%	411	4.1%

#### Travel Time (2019)

Travel to Work in 14 Minutes or Less	364	28.5%	715	28.2%	2,180	21.5%
Travel to Work in 15 to 29 Minutes	282	22.1%	609	24.0%	3,047	30.1%
Travel to Work in 30 to 59 Minutes	620	48.6%	1,163	45.8%	4,347	42.9%
Travel to Work in 60 Minutes or More	66	5.2%	136	5.4%	881	8.7%
Average Minutes Travel to Work	30.1		29.0		28.4	

This report was produced using data from private and government sources deemed to be reliable. The information herein is provided without representation or warranty.